

CAMCAT®

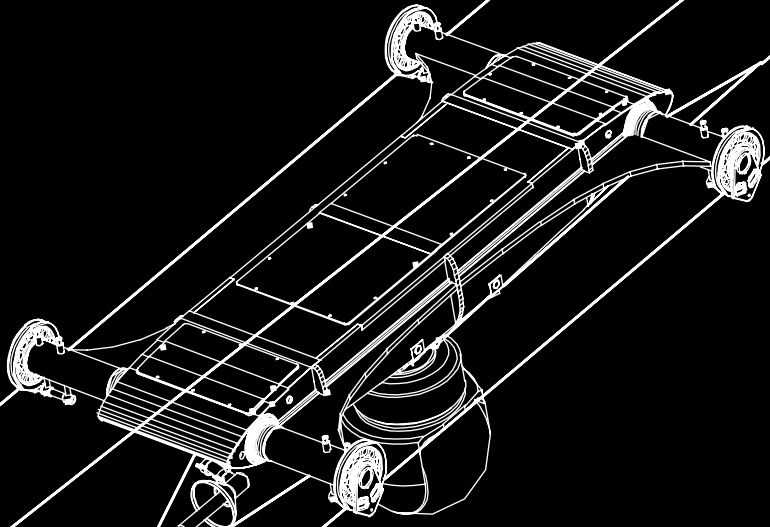

2018⁺

CAMCAT®

WWW.CAMCAT-SYSTEMS.COM

TABLE OF CONTENT

P.04	THE CAMCAT® SYSTEM
P.08	STANDARD SYSTEM
P.10	HIGHSPEED SYSTEM
P.12	2D SYSTEM
P.14	COLIBRI SYSTEM
P.16	HIGH TENSION SYSTEM
P.18	VERTICAL SYSTEM
P.20	LINEAR SYSTEM
P.22	GIMBAL SERVICE
P.23	GYROCOPTER SERVICE
P.25	FURTHER DEVELOPMENT



Philosophy

A. Brozek / T. Schindler

Since many years Camcat®-Systems is developing and providing different cable camera systems for their customers. The challenge is always to find well working solutions for the clients in the best and safest way.

The technical team of Camcat®-Systems is always in close contact with the broadcasters and knows in detail what they need. During all these years many different types of cable camera systems were developed and if required the team works out individual solutions for special requests. Exactly this kind of special service in combination with experience and technical knowledge is what the clients need and honour.

Because of this close contact a lot of clients became partners which is a great compliment for us.

For all solutions one of the most important facts is the safety of the installation - for operator staff as well as for public and actors. Therefore all parts are checked and certified by the German Health and Safety Group (TÜV) - one of the strictest industrial safety authorities in the world.

The CAMCAT® System

More than 25 years of constant improvements and innovations make the CAMCAT® system a reliable partner that is still hungry for new exciting challenges.

Developed in the Nineties and continuously improved the CAMCAT® System provides unique and stunning pictures from otherwise unobtainable perspectives, indoors and outdoors.

Images created by the CAMCAT® System have inspired the audience of film and TV around the globe demonstrating a unique spectacle on the screen. Over the years its reliability and high quality have been proved on many occasions in sports, entertainment, documentary and films as one can learn from our references.

You can find clients of Camcat®-Systems around the globe on all continents. These clients are very satisfied about the quality and the power of the system and the team of Camcat®-Systems. They are clients and partners for many years.

In the business we often hear the opinion - "If you cannot find a technical solution for a request, then go and contact the team of Camcat®-Systems. They can help you". We are very proud about feedback like this and it pushes us to go forward in developing new solutions for our costumers.

Introduction

How the system works

“One of the main criteria for us at the development of new systems is a modular construction and the compatibility so that it can be integrated in the CAMCAT® environment.”

The CAMCAT® System is a fully remote controlled cable camera system which achieves precise camera motion over distances up to 2500m at any conceivable angle and at speeds up to 130km/h with maximum stability and smoothness. Since the CAMCAT® System is based on a modular construction it can be adapted to a wide range of shooting situations.

The camera buggy runs on two independent guide ropes made of heavy duty synthetic material and can accept a range of payloads from open platform stabilised mounts fitted with film cameras, to HD/4K stabilised mounts with integrated camera and lens.

The latest RF technology or fibre connections are utilised for picture transmission, camera and head control data to and from the camera buggy with an on-board battery providing seamless operation.

The computerised remote controlled system is backed by an especially developed software that enables the two operating CAMCAT® technicians to pilot the CAMCAT® System either manually or in a preprogrammed automatic control mode.



As safety is a top priority the CAMCAT® System complies with highest standards and is certified by German based TÜV Health and Safety Group, one of the strictest industrial safety authorities in the world. With this certification we are allowed to fly over athletes and the audience.

The system and the crew is trained and ready to :

- Operate over audience, athletes and artists. (major sport events, concerts, feature film,...)
- Rig and operate the system in harsh and exposed environments. (mountains with helicopter rig, desert, buildings, structures,...)
- Rig and operate the system on or in historic monuments or buildings.

sensitive locations
no problem



Standard System

Technical data: *CAMCAT® Standard*

- **Maximum speed**
70km/h (44mph) or 19,5m/s
- **Maximum acceleration**
3,25m/s² (in 6sec or 57m at top speed)
- **Track length**
up to 1000m (3280ft) longer length on request
- **Dimensions base station**
 length: 5m
 height: 1,5m - 4,5m
 width: 2,6m
 weight: 650kg

The *CAMCAT®* Standard System

The all-rounder and the first system that was developed to realize stunning pictures from over the scenery. Based on the principles and the experience of the Camcat® Standard all other Camcat® systems were developed. It is still one of the most used systems.



The CAMCAT® STANDARD is an advanced, fully remote controlled cable camera system designed to run between two fixed points up to 1000m apart at speeds of up to 70 km/h. Just on one of these two points infrastructure like power and data lines are needed. The other one functions just like a deflection point for the ropes.

The CAMCAT® STANDARD camera buggy can accept a wide range of payloads. You can use multiple open platform stabilised mounts fitted with different film cameras even with heavy payloads like big 3D rigs. Beside this the system is capable to use stabilised mounts with integrated camera and lens.

For special applications the buggy can also be rigged with multiple sensors.

Examples of open platform stabilised mounts:

Flight Head, Libra Head, Scorpio Head, Stab-C, Mini-C, ...

Examples of stabilised mounts with integrated camera and lens:

GSS, Cineflex, Shot Over, Wescam, ...



Certified by German Health and Safety Group (TÜV) including BGVC1

CAMCAT® Highspeed

The CAMCAT® Highspeed was developed out of the CAMCAT® Standard System. In creating the system its goal was to deliver spectacular images from high speed sporting events like motor-sports or alpine skiing. Until now this is still the main use of this system.

The CAMCAT® Highspeed, a variant of the CAMCAT® STANDARD, is an advanced, fully remote controlled cable camera system designed to run between two fixed points up to 750m apart at speeds of up to 130 km/h. Just on one of these two points infrastructure like power and data lines are needed. The other one functions just like a deflection point for the ropes.

The CAMCAT® camera buggy can accept a wide range of payloads. You can use multiple open platform stabilised mounts fitted with different film cameras even with heavy payloads like big 3D rigs. Beside this the systems is capable to use stabilised mounts with integrated camera and lens.



Technical data: CAMCAT® Highspeed

- **Maximum speed**
 130km/h (80mph) or 36m/s (higher speed on request)
- **Maximum acceleration**
 up to 10m/s² (in 2,8sec from 0 to 100km/h)
- **Track length**
 Standard length 750m (2460ft)
 longer length on request
- **Dimensions base station**
 length: 5m
 height: 4,5m
 width: 2,6m
 weight: 1200kg



Certified by German Health and Safety Group (TÜV) including BGVC1

Highspeed System
 The fastest cable camera system



Technical data: CAMCAT® 2D

- **Maximum speed horizontal**
54km/h (34mph) or 15m/s
- **Maximum speed vertical**
18km/h (11mph) or 5m/s
- **Track length**
standard length 350m (1148ft)
longer length on request
- **Dimensions base station**
length: 5m
height: 4,5m
width: 2,6m
weight: 1600kg

2D - System

The CAMCAT® 2D - System

The CAMCAT® 2D adds an additional dimension into the linear movement of the Standard System. Beside the movement from point to point this system can also lower the camera platform to achieve even more spectacular images. It is mainly used for movies and big sporting events.

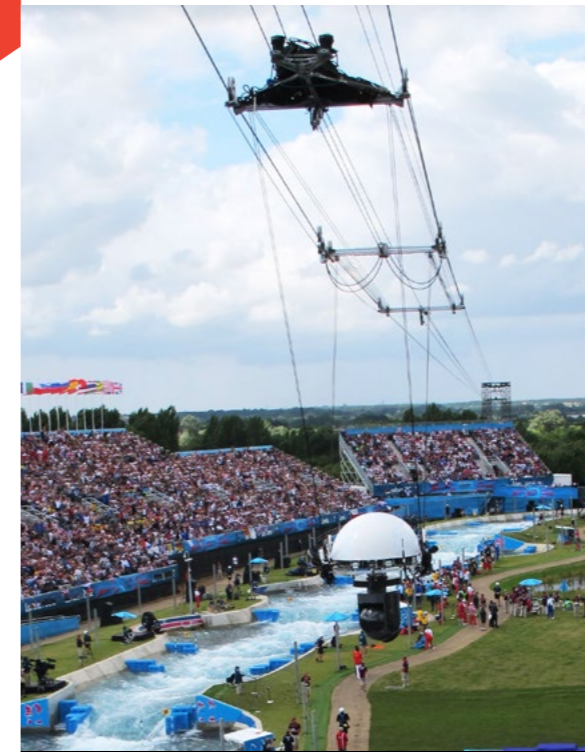

The CAMCAT® 2D, a variant of the CAMCAT® STANDARD, is an advanced, fully remote controlled cable camera system designed to provide a two-dimensional camera movement, vertical and horizontal, between two fixed points up to 350m apart at speeds of up to 54 km/h. Just on one of these two points infrastructure like power and data lines are needed. The other one functions just like a deflection point for the ropes.

At the CAMCAT® 2D the buggy on the ropes is separated to one that stays on the guiding ropes (buggy) and a second part that can be moved up and down. We call this Flightdeck. The Flightdeck can accept

a wide range of payloads. You can use multiple open platform stabilised mounts fitted with different film cameras even with heavy payloads like big 3D rigs (up to 100kg). Beside this the systems is capable to use stabilised mounts with integrated camera and lens.



Certified by German Health and Safety Group (TÜV) including BGVC1





Colibri System

The small light and agile system.

CAMCAT® Colibri

The CAMCAT® Colibri was released because of the need for smaller lighter cable camera systems that still reach the quality of high end cable rigs. It performs excellent in the world of live broadcast around the world. No matter if it is motor-sports or other events like classical concerts or golf.

The CAMCAT® - Colibri finds its place in the CAMCAT® family where the proven systems of the CAMCAT® are too large and the requirements are not that extreme (wind, weather, acceleration or track length), although the performance and features are the same like in the bigger systems.

In an intensive process with our clients we defined the parameters for the CAMCAT® - colibri. In the end our developers were able to optimize the system with respect to safety, quality and efficiency.

The result is a small cable camera (50 cm track width) that needs just very little tension forces because of the low weight. The force here in this system is less than 1/3 of the bigger systems. With this especially the endpoints of the track do not need the same strength like at the other systems. This reduces the cost for the client significant.

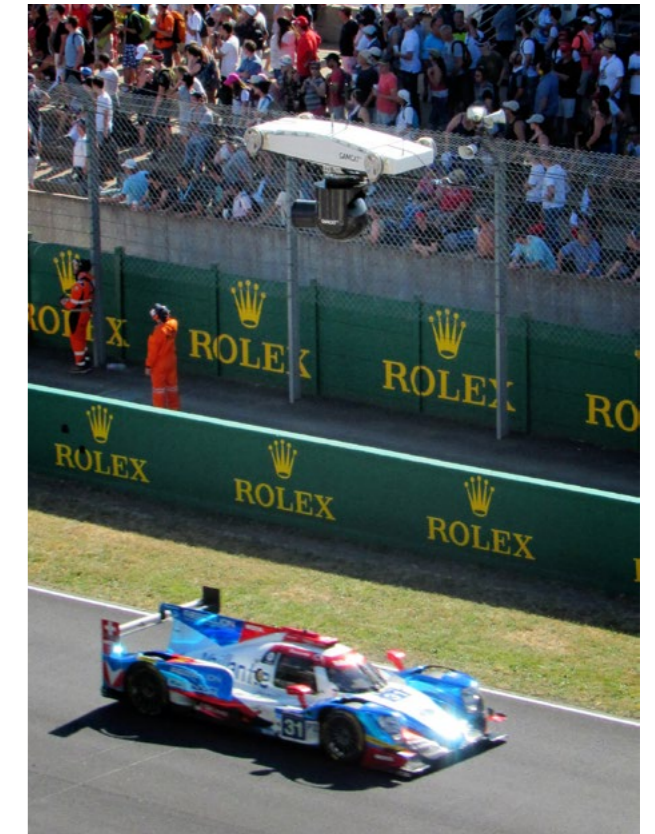

Technical data: CAMCAT® Colibri

- **Maximum speed**
54km/h (34mph) or 15m/s
- **Maximum acceleration**
3m/s² (from 0 to top-speed in 4,6sec)
- **Track length**
maximum length 350m (1148ft)
- **Force in the system**
maximum 800kg
including wind and dynamic



Certified by German Health and Safety Group (TÜV) including BGVC1



High-Tension System

Technical data: *CAMCAT® High-Tension*

- **Maximum speed**
70km/h (44mph) or 19,5m/s
- **Maximum acceleration**
3,25m/s² (in 6sec or 57m at top speed)
- **Track length**
from 1000m to 2500m (8200ft) longer length on request
- **Dimensions base station**
length: 5 - 7m
height: 10m -15m
width: 2,6m
weight: 1600kg

The *CAMCAT®* High-Tension

This is a wire camera rig built to go to the extreme. Whenever the distance is too long for a classic cable camera rig, the CAMCAT® High-Tension is capable to do it. With this system Camcat® Systems has successfully reached track-lengths over 2400m on major sports events.



The CAMCAT® High-Tension is an advanced, fully remote controlled cable camera system designed to run between two fixed points from 1000m to 2500m apart at speeds of up to 70 km/h. Just on one of these two points infrastructure like power and data lines are needed. The other one functions just like a deflection point for the ropes.

To achieve lower fixing points for the track, the total force in the system is much higher than with all the other systems. If we compare it with the normal forces the endpoints here just need to be 1/3 of the height for a 2400m track.

The CAMCAT® High-Tension camera buggy can accept a wide range of payloads. You can use multiple open platform stabilised mounts fitted with different cameras or it is possible to use stabilised mounts with integrated camera and lens. (like GSS, Cineflex, Shot Over, ...)



Certified by German Health and Safety Group (TÜV) including BGVC1

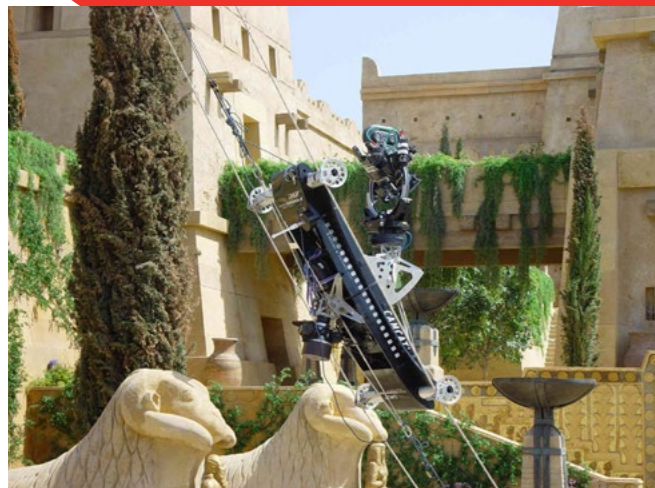

Technical data: *CAMCAT® Vertical*

- **Maximum speed**
26km/h (16mph) or 7,2m/s
- **Maximum payload**
100kg depending on the system
- **Track length**
up to 300m depending on the system
- **Dimensions base station**
length: 3,2m
height: 1,1m
width: 2,1m

Certified by German Health and Safety Group (TÜV) including BGVC1

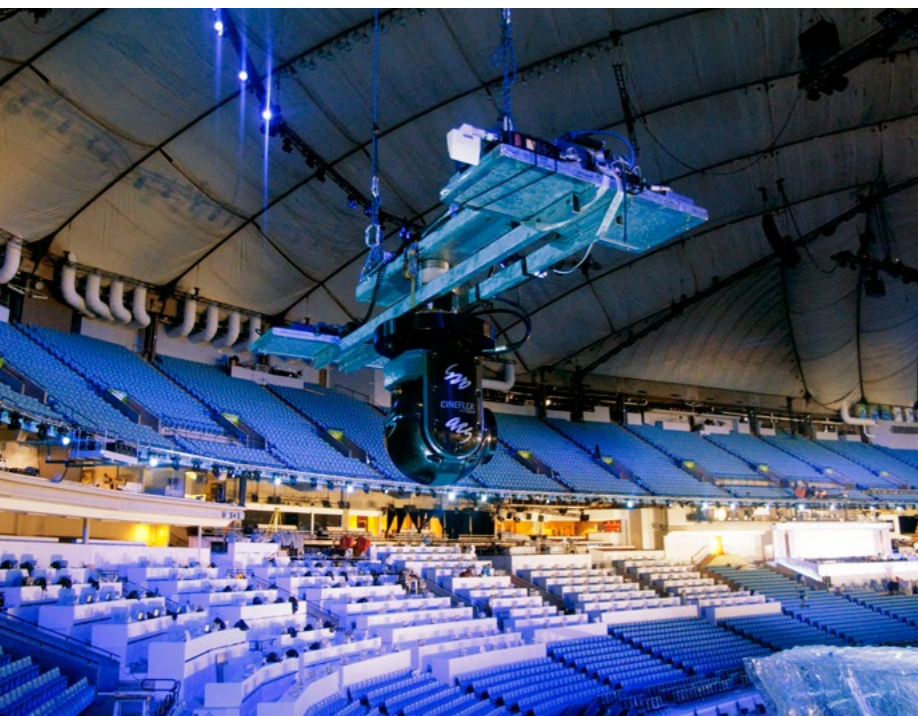

The *CAMCAT®* Vertical System

A flexible and easy to install system to reach higher perspectives up to 300m. 3 sizes guarantee that the client finds the right system for the length and purpose.

The CAMCAT® Vertical, a variant of the CAMCAT® Standard, is an advanced, fully remote controlled cable camera system designed to run between two vertical fixed points up to 300m apart at speeds of up to 26 km/h.

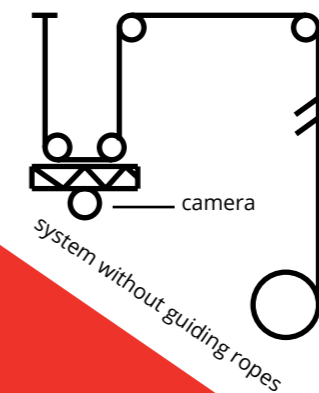

The system can be used with guiding ropes to achieve a maximum of control and stability. With this option it is also possible to realize angles from 30° to 90°.

It can also be used without guiding ropes in a free hanging mode. In this way the whole area 360° under the flight-deck is free without disturbing ropes. Depending on the size of the system a wide range of stabilized mounts and cameras can be used. From very small up to payloads from 100kg.

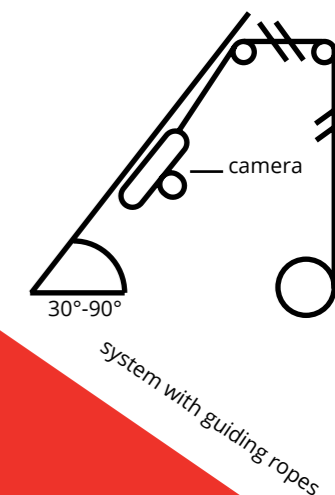

Vertical System



CAMCAT® linear

The CAMCAT® linear is a development based on the CAMCAT® Standard, and the CAMCAT® 2D. The aim was to realize stable linear camera movement (no sag of ropes) without the usage of a rail with the excellent performance of the well known CAMCAT® system.

The system is an advanced fully remote controlled and programmable camera system. Although the CAMCAT® linear accepts a wide range of payloads from heavy to lightweight, the primary design was to work with a lightweight system to reduce the forces and the heights at the anchor points to a minimum.

The system is based on a combination of a Camcat® Colibri and a Camcat® 2D. Like the Colibri System it is a small light system that runs with 50cm -70cm track width (distance between the two guiding ropes).

The system is operated with a modified Colibri buggy. With this system height adjustments of the Camera are possible like with the 2D system but they are mainly intended to compensate for level differences on the ground. The system may be used on a flat or sloping ground.

In contrast to the 2D system, the camera is here still on the buggy and not on a separate flight-deck. As a result, the buggy is very stable. Besides this the Camcat® linear buggy is lighter than the 2D Flightdeck so the linear system can use its lower weight and stability with the suspension ropes to act more quickly and accurate.

The system is suitable as a replacement for rail systems. Wherever the ground is too difficult or too unstable for a massive rail construction, the system can show its strengths. Even with longer distances, there are also cost advantages over a rail system, as rails are more expensive than a rope in comparison.



Technical data: CAMCAT® linear

- **Maximum speed**
 70km/h (80mph) or 19,5m/s (higher speed on request)
- **Maximum acceleration**
 3,25m/s² (in 6sec or 57m at top speed)
- **Track length**
 Standard length 500m (1640ft)
 longer length on request
- **Dimensions base station**
 length: 3m
 height: 1m
 width: 2m
 weight: 500kg

Certified by German Health and Safety Group (TÜV) including BGVC1





Gimbal Service at *CAMCAT®-Systems*

With the GSS B512 (Cineflex) Camcat®-Systems can offer the best stabilized platform option for broadcast payloads. With five-axis stabilization and in an extremely small package, this gimbal only weighs 16kg (35 lbs), without payload, making it lightweight and versatile!

Camcat® Systems can look back on many years of good partnership with Gyro Stabilized Systems (GSS). As the first customer of this platform we worked together with GSS in getting the B512 (Cineflex) to life.

The good relation to GSS

and the knowledge of the system made us also to an official service point for GSS gimbals.

Besides the gimbals Camcat® Systems owns, we can rely on a big network if more gimbals are needed for big events.

System Specs GSS B512 (Cineflex)

- **Gimbal performance**
5-axis advanced fiber optic gyro-stabilization
Azimuth: 360° continuous
Elevation: 35° to -210° from horizontal
Roll: +/- 90° (steerable/stabilized)
Gimbal slew rate: 0-130°/second Max operational airspeed: 200 knots
- **Electrical**
VIN: 18-33 VDC
Power: 15 amps max draw at 28 VDC
- **Dimensions**
Gimbal width: 347 mm; Gimbal height: 450 mm;
Snout length: 0-152 mm Cable set length: 6m-30m
- **Weight**
Platform: 35 lbs (15.9 kg) + payload Laptop Control Unit: 7 lbs (3.2 kg) Auxiliary Junction Unit: payload specific Cable Set: 8 lbs (3.6 kg)
- **Environmental**
Operating temperature: -20° to 50°C. Sealed system for airborne/ground/marine applications

Gyrocopter with *CAMCAT®-Systems*

For some places this is an interesting and economic alternative to classical helicopter aerials.

The Gyrocopter is manned with two persons. The pilot and the gimbal operator. Besides this all the equipment for a professional broadcast transmission finds place in this vehicle. Compared to a helicopter the Gyrocopter is quieter and has no down-wash.

It is driven by the propeller on the back side. The rotor on top of the aircraft works like a rotation wing that is just powered by the wind of the movement.

The compact and light weight construction also requires a minimum of hangar space and allows easy transportation on trailers or in enclosed mobile hangers.

A gyrocopter is also capable to fly in stormy winds up to 100 km/h and can reach altitudes up to 4500m (15000ft).

In this version it is equipped with a GSS Cineflex (B512) gimbal, and a picture down link, for a rock solid coverage in a high end live broadcast environment in 4K and HDR.



Technical Data of *TRIXEYE gyrocopter*

- Flying capabilities in stormy winds of 55 knots (100 km/h)
- Operation temp. range from -20° to + 50° C
- Night flying capability with modern instruments and IR screen
- Take-off roll less than 75m (250 ft) unpaved Landing roll less than 30m (100 ft) unpaved
- Endurance depending on payload from 2,5h to 4,5h
- Slow flying capability for observation at 22 knots (40km/h)
- Maximum altitude of 15,000 ft (4,500 m)
- Payload of 280kg (620lb)
- Optional skids, floats and bosh wheels available



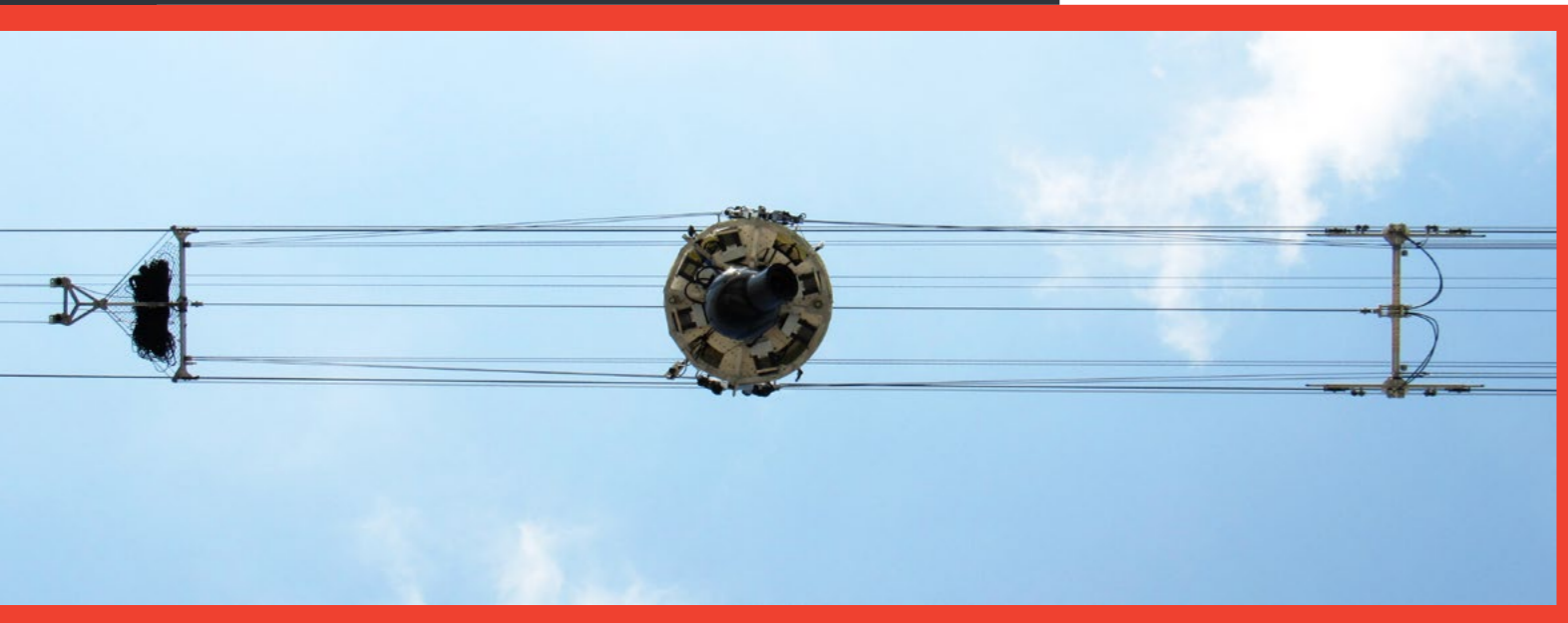

FURTHER DEVELOPMENTS



GCU-BOX - Gimbal Control Unit

These boxes were developed mainly for the purpose to radio control the GSS gimbals. The GCU-Box combines the different commands from the hand controller and sends it one way to the gimbal. Internally programmed backup systems are in place to overcome possible radio disturbance. If required a back channel may be added but the device was developed to also work just in one direction.

You can also use the device to separate the gimbal from the control laptop via serial cable over very long distance.



Flight OCP - for Grass Valley cameras

This Flight-OCP was as well totally designed, engineered and programmed at Camcat® Systems. Its purpose is to be used in aerial applications like in helicopters or gyrocopters instead (or additional) to the OCP 400 from Grass Valley. We developed this device in close cooperation with Grass Valley to ensure a seamless work-flow.

One of the big advantages of this system is that you can use it together with the OCP 400 in a "bypass mode". Here you can hand over the control without re-cabling and restart of the camera.



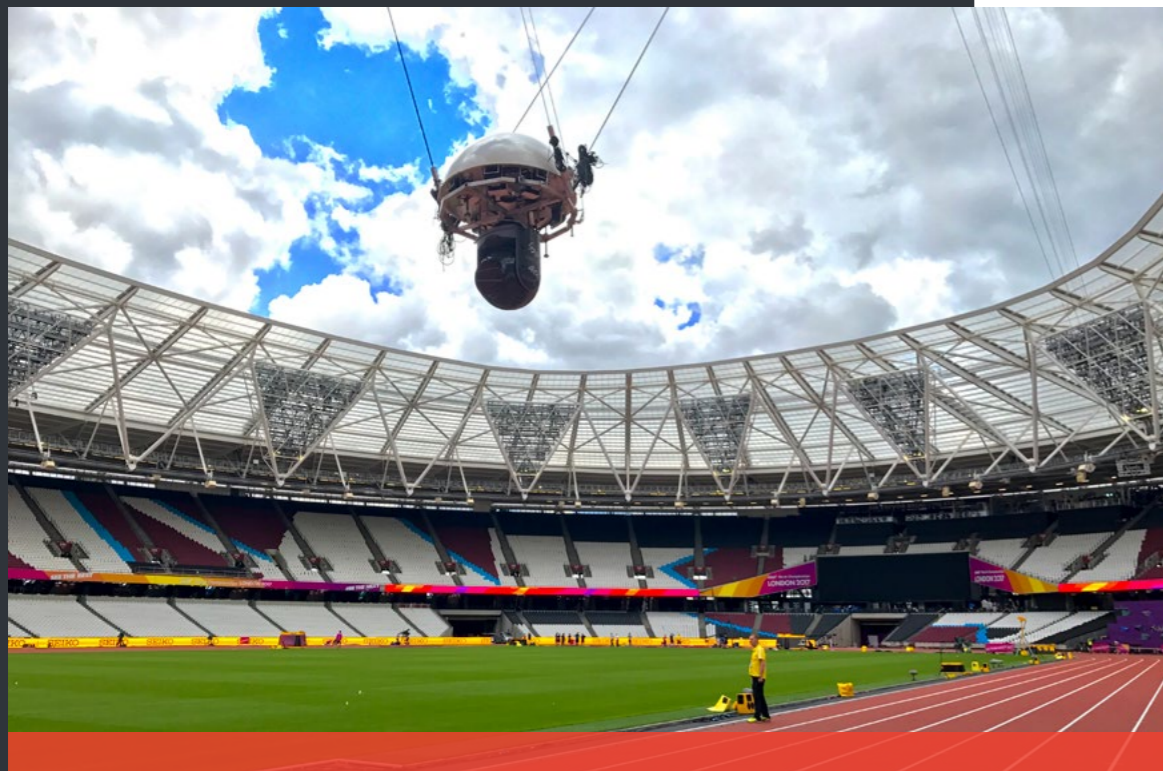

REFERENCES (a selection)

- OBS, Winter Games, Pyeongchang, Korea, 2018
 FOM, Formula 1, complete season, 2014-2018
 ITV, Grand National Aintree – Horserace, GB, 2000-2018
 Gearhouse Broadcast, V8 Supercars, Bathurst, Australia, 2017, 2018
 ORF, Life Ball, Vienna, AUT, 2005-2007, 2009-2015, 2017, 2018
 Aurora Media, Formula E race Berlin, Rome and New York, 2018
 ORF, Philharmonic Orchestra, Schönbrunn, Vienna, AUT, 2010-2018
 ACS, The Ryder Cup, Le Golf National, FRA, 2018
 ITV, Royal Ascot – Horserace, GB, 2000-2018
 ITV, Aintree Horserace, GB, 2013-2018
 ITV, Cheltenham – Horserace, GB, 2017, 2018
 AMP – 24th Le Mans, FRA, 2016-2018
 ACS, Golf The Open, Scotland, 2017, 2018
 HR – Europa Open Air Concert/Weseler Werft, GER, 2017, 2018
 ISB, European Paralympic Athletics Championships Berlin, GER, 2018
 Kitz Air, Bergdoktor/television series, AUT, 2018
- Aurora Media, Formula E race, Berlin, GER, 2017
 ACS, IAAF World Championships, London, GB, 2017
 CTV – 4th Islamic Solidarity Games, Baku, Azerbaijan 2017
 ORF, Ski race „Kitzbühel Hahnenkammrennen“, AUT, 2014 - 2017
- OBS, Summer Games, Rio, BRA, 2016
 ZDF, Ski Jumping, Oberstdorf, GER, 2001-2016
 ZDF, Ski Jumping, Garmisch-Partenkirchen, GER, 2002-2016
 Wige Media AG – 24 hrs Nürburgring, GER, 2016
- ARRI Rental, Eddie the Eagle/Film, Oberstdorf, GER, 2015
 DUBAI FILM LLC , Endurance Race, Dubai, 2015
 CSSG, IAAF World Championship Beijing 2015, China
 InFocus TV, Formula E race, Berlin, GER, 2015
 EPC, WCS Beaver Creek, USA, 2015
- OBS, Winter Games, Sochi, RUS, 2014
 Al Kass Sport Channels , Emir Cup, Doha, Qatar, 2014
 ORF, Opening of the festival weeks 2014, AUT
- Uniart Media, 12 National Games, China, 2013
 Fox, Daytona 500, Nascar, Florida, USA, 2013
 CZ Television, Biathlon WM 2013, Czech Rep, 2013
 Opus, Jazz open, Stuttgart, GER, 2013
 ORF, Vienna Philh. Orchestra, New Years Concert, AUT, 2012, 2013
 ORF, WC-Final, FIS Ski Alpin, AUT 2012, 2013
- OBS, Summer Games, London, GB 2012
 FOM, Formula 1, Grand Prix Silverstone, Hockenheim, Budapest, GB, GER, H, 2012
 BBC/ITV, Royal Ascot – Horserace, GB, 2000-2012
 Uniart Media, Fuzhou Moonfestival, China, 2012
 ACS, Robbie Williams O2-Arena, London, GB, 2012
 NBC Today Show – Election Night, New York City, US, 2012
 ORF, Philharmonic Orchestra, Schönbrunn, Vienna, AUT, 2010-12
 ORF, Life Ball, charity, Vienna, AUT, 2005-2007, 2009-2012
- FOM, Formula 1, Grand Prix Silverstone, GB, 2011
 IGBS, 7th Asian Winter Games, Kasachstan, 2011
 Uniart, Shanghai World Swimming Championship, China, 2011
 Warner Bros., Jack the Giant Killer, 3D, GB 2011
 EXIT, Reopening of Grosny-City, Chechenya, 2011
 Gearhouse Broadcast, Winter Universiade, Turkey, 2011
- Constantin Film, Atmen, AUT, 2010
 Apaches Entertainment, The Impossible, ESP, 2010
- OBS, Winter Games, Vancouver, CAN, 2010
 EXIT, 65th Anniversary of Victory WW2, Moscow, RUS, 2010
- CCTV, 60th Anniversary of P.R.C., Beijing, China, 2009
- Olympic Venue Film, China, 2008
 BR, SKI-Flying World Cup, Oberstdorf, GER, 2008
 BOB, Sumer Games, Beijing, China, 2008
 Globo (BR), Carnival in Rio, Rio de Janeiro, BRA, 2007, 2008
- RTL, Formula 1 – Hockenheim, GER, 2002-2006
 Final game FIFA World Cup 2006, GER, 2006
- Globo (BR), Formula 1 – Sao Paulo, BR, 2007
 Uniart Productions, Beijing Happy Valley, China, 2007
 Uniart Productions, Beijing Happy Valley, China, 2007
 Toastie, Narnia II: Prince Caspian, PL, 2007
 China Best Media Advertising, Pre-Olympic Show, China, 2007
- Garage Films, SONHO – commercial, PL, 2006
 Gerard de Thame Fils Ltd., Quixtar – commercial, GB, 2006
 Goodgate Productions, VISA – commercial, GB, 2006
 TOBO, Winter Games, Torino, Italy, 2006
 Uniart Prod., Nanning int. Folk Song Festival, China, 2006
 KPS, 50th anniversary of Lottery operator Sazka, CZ, 2006
 ORF, UCI Road World Championships, AUT, 2006
 TV3, Formula 1 – Barcelona, ESP, 2006
- France 2, French Open, Paris, FRA, 1999-2005
 Blink Productions, UPS – commercial, CAN, 2005
 The Goal Ltd., The Goal II, GB, 2005
 20th Century Fox, Eragon, GB, 2005
 WDR, 20th World Youth Day, Cologne, GER, 2005
 ORF, Champions League matches, Vienna, GER, 2005
 ORF, soccer match Austria vs. Ireland, Vienna, GER, 2005
 ORF, SKI-Flying World Cup, Kulm, Austria, AUT, 2005
 Austrian Federal Ministry of Defence, Military Parade, AUT, 2005
 BR, Nordic Ski World Championships, Obersdorf, GER, 2005
 VEK, Red Square, Victory Day celebrations, RUS, 2005
- Channel 4, Cheltenham – Horserace, GB, 2000, 2003, 2004
 Red Square Inauguration President Putin, RUS, 2004
 NDR, Kreml – documentary, Moscow, GER, 2004
 Warner Bros, Harry Potter and the Goblet of Fire, GB, 2004
 TVE, Opening Forum Barcelona, ESP, 2004
 TVE, The Royal Wedding, ESP, 2004
 ZDF, Wetten, dass ... ?, GER, 2004
 BR, Nordic Ski World Cup, Oberstdorf, GER, 2004
 AOB, Summer Games, Athens, Greece, 2004
- SF DRS, Alpine Ski World Championships, CH, 2003
 Filmservice München, Mercedes – commercial, GER, 2003
 Widescope Productions, Nike-commercial, GB, 2003
 RTL, Moto-GP Sachsenring, GER, 2003
 SAT1, champions League matches, Munich, GER, 2003
 Warner Bros, Troy. Malta/Mexico, 2003
 Warner Bros, Harry Potter – Prisoner of Azkaban, GB, 2003
 TVRS, World Athletics Championships, Paris, FRA, 2003
 Channel 4, York – Horserace, GB, 2003
- BBC, Epsom – Horserace, GB, 1999-2002
 Laszlo Kadar Film, Dallmayr commercial, GER, 2002
 Wiener Klappe, Karlsberg Falken-Beer – commercial, AUT, 2002

contact information:

CAMCAT® Systems GmbH
Josef Perger Strasse 4a
3031 Rekawinkel
Austria

phone: +43 660 66 77 505
mail: office@camcat-systems.com
web: www.camcat-systems.com
